



710 series

wrap around packer



710 Series - wrap around packer

TREPKO wrap-around packers are fully automatic machines which group and pack products in cases or trays formed from a flat sheet of corrugated board. The flat sheet, referred to as a 'blank', is folded and glued around the pre-arranged products to form the case/tray.

The machine consists of flexible basic modules designed to meet the current customer requirements with regard to pack type and size and also allows for future additions if and when they are required.

The machine is designed incorporating unique & interchangeable 'blank' feeders to allow different case/tray sizes to run on the same machine. This changeover procedure requires little time with all the different sized change parts easily & quickly accessible.

All packaging takes place at one level with a maximum output speed of 20 cases per minute. The machine can also be loaded with several 'blank' stacks for longer runs without the need for loading.



Optimum folding principle

TREPKO's box folding principle provides the optimum folding sequence, which results in a true rectangular box. Incorporating the straight flap edge in the construction of the box actually increases its stacking strength by approximately 15%. The unique folding principle also means we are not dependent on the packaging enclosing the customer's product which as a result means that we are less sensitive to tolerance with regards to both the product and the cardboard blank.

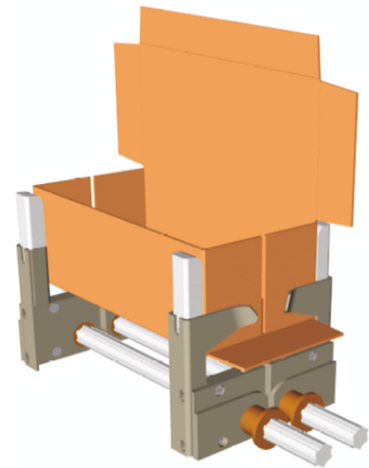

Box solutions

TREPKO can handle most box solutions in the same packaging machine. The company has developed almost as many box alternatives as packaging machines in order to satisfy the demand for display box, print, perforations, etc. These are based on the basic models; wrap-around, tray, tray with lid etc.

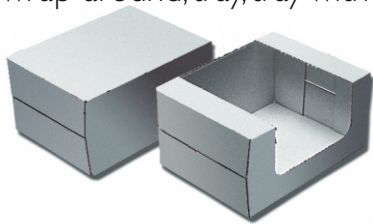

Wrap-around

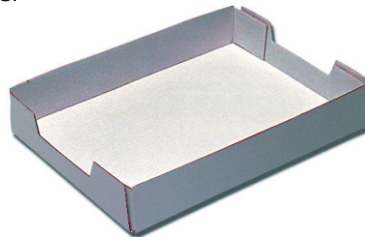

Tray



Tray with lid

Tailor – made grouping solutions

The TREPKO design department is continuously developing new tailor-made grouping solutions to meet the wishes and requirements of our customers. These solutions allow for different patterns and arrangements to be achieved, in so doing improving the impact of the product at the POS.

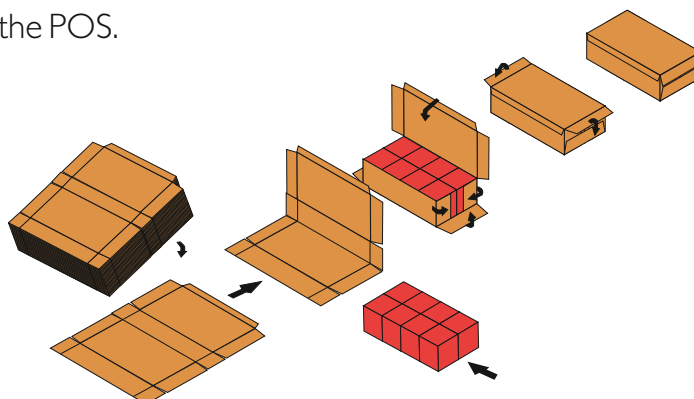

Examples of grouping products

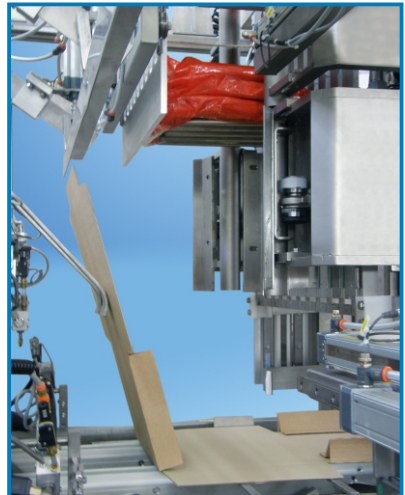
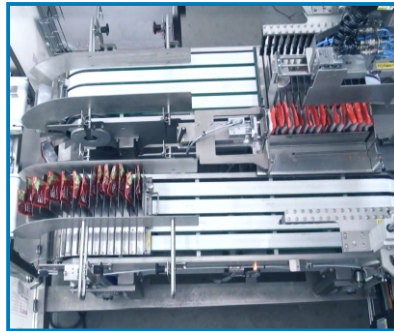
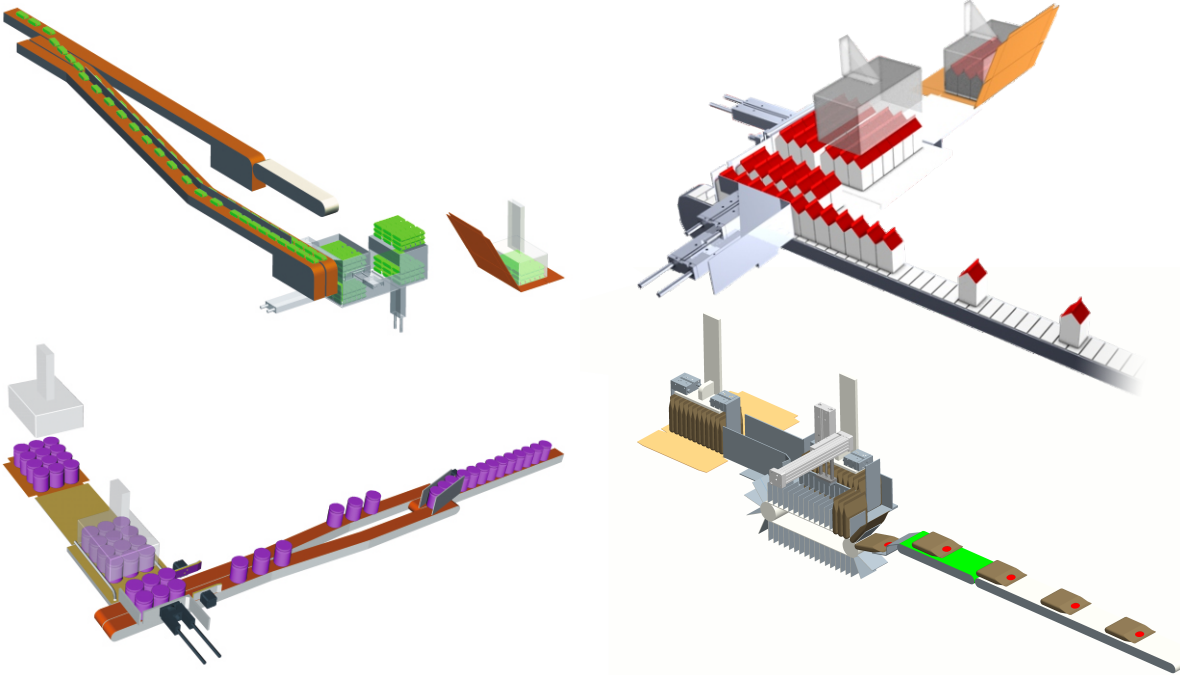

710 machine integrated with a TREPKO brick wrapper





Worldwide supplier 
of filling/packaging machines



info@trepko.com
www.trepko.com