

Trepko



620 series
filling systems

Cam Kavanoz
Dolum Makinası

620 series

The 620 Series from TREPKO includes a rich and diverse group of equipment for the filling of liquid and semi-liquid products into pre-formed containers. Every machine from this series employs established manufacturing methods and uses only high-quality materials.

This range of equipment starts with simple semi-automatic product depositors that fill product into manually placed containers. Most often this arrangement has either one or two lanes.

Another 620 Series variation are machines which can be integrated with other packaging equipment, like e.g. FFS machines. Depending on the requested output or number of lanes in the packaging machine, these filling stations are usually offered in a one to four lane version. Another possibility is given by the moving filling heads which perform two filling strokes per one cycle of the FFS machine. Full capacity of the integrated equipment is thus achieved.



Options

PACKAGING HYGIENE
Sterile Air Cabin
CIP/SIP of the Filling System

PRODUCT INFEEED
Hopper with Agitator & Level Control
Hopper Heating
Compensator

EFFICIENCY
Double Filling
Automatic Volume Adjustment



The 620 Series also includes filling machines equipped with slat conveyors for container supply and collection. One example of this setup include units with scrolls for transportation of glass jars. Depending on the production size these filling systems are designed with between one and eight filling heads, while the glass jars are moved in either one or two lane batches.

The 620 Series can easily be integrated into a glass jars filling & closing line. Such lines are designed for filling processed cheese into glass tumblers or cylindrical jars closed with pull-off or twist-off caps. Their output ranges from 2,400 up to 10,000 jars/hour.



Typical Glass Jars Filling Line

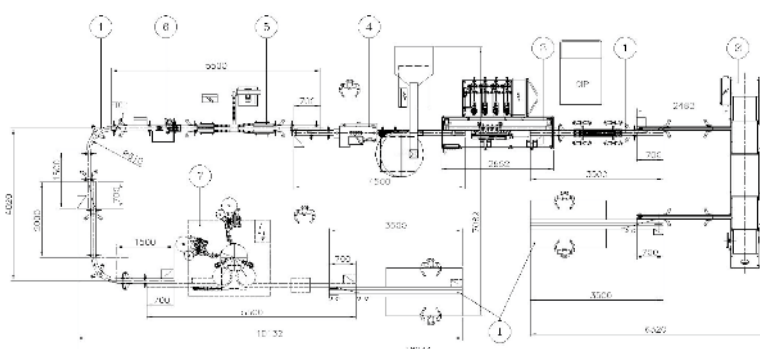

Line components:

1. Conveyors
2. Jars blowing & rinsing machine
3. 620.4.T.I: TREPKO's 4-head dosing machine
4. Capping machine
5. Drying unit
6. Vacuum detector
7. Labelling machine

Optional equipment:

- Sterilisation & Cooling Tunnel
- Metal & Glass Detectors
- End-Packing Machines



Worldwide supplier 
of filling/packaging machines

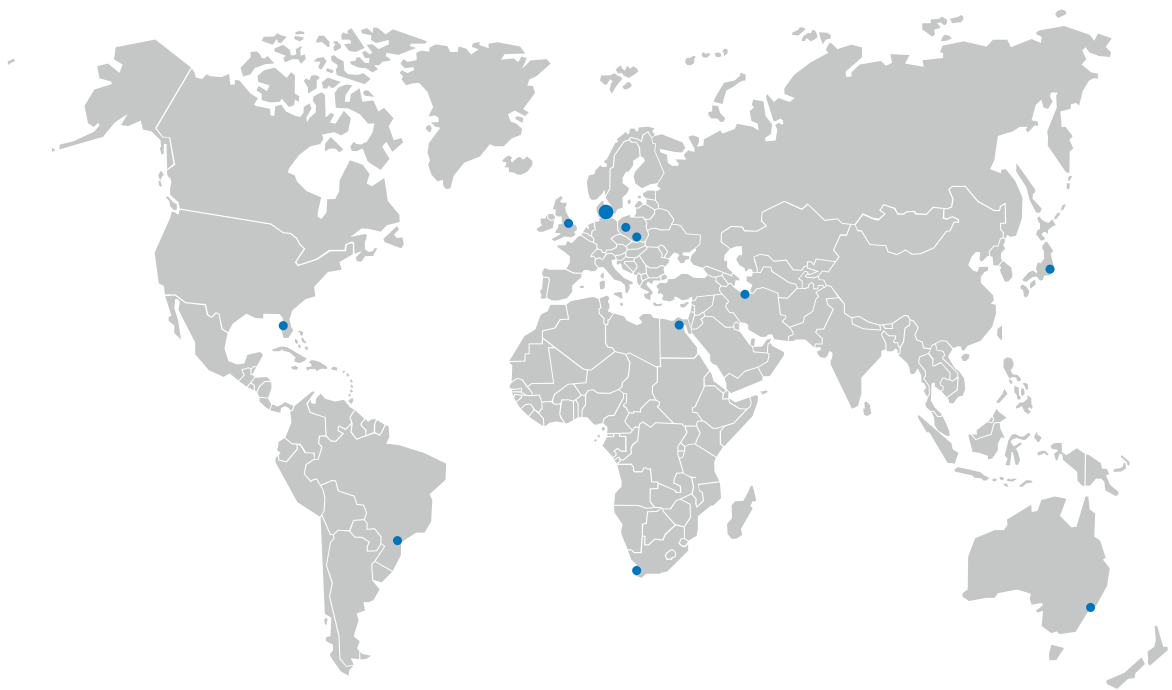

info@trepko.com
www.trepko.com